

## FPO 80

Tank truck vane pump



**Alfons Haar**

### Self-priming vane pump

- depending on selected pump size up to 1230 l/min with  $\Delta p = 10$  bar

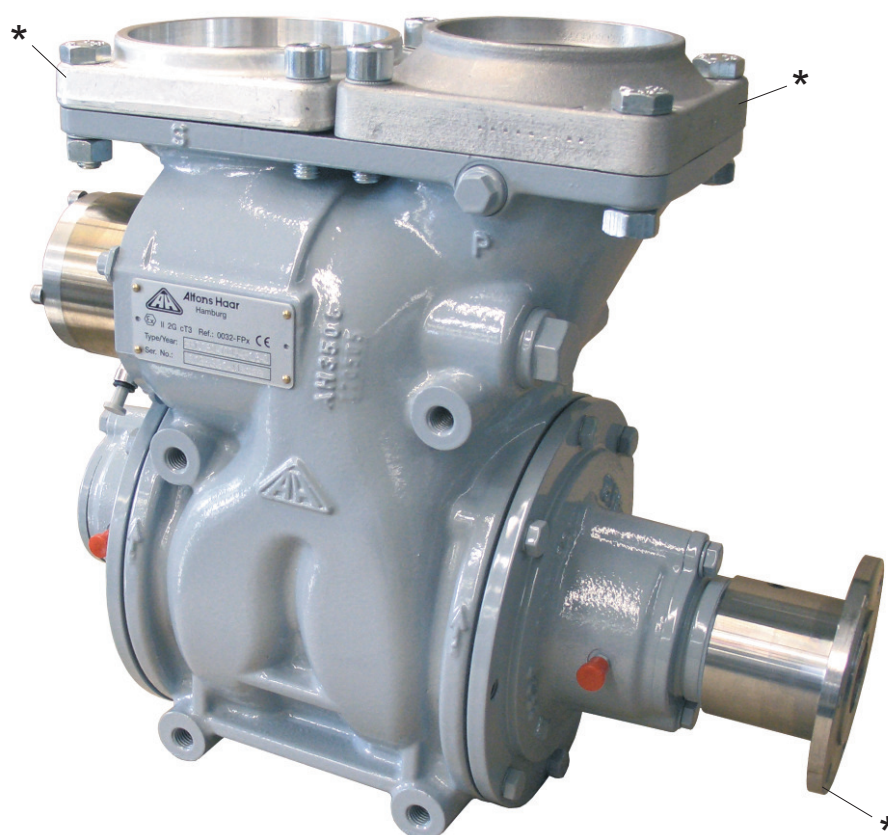

**The Alfons Haar pump is Ex II 2G cT3 CE certified,  
an operating without a flame arrestor\*\* is possible !**

- computer optimized 4" to 3" suction cross section for a quiet pump operation and high discharge rate
- large integrated pneumatic or mechanical by-pass valve
- ideal 4" and 3" block flange for connection of the pipework to the pump in the tank truck
- very good blow down for product change
- excellent working life and simple service
- PTO or hydraulic drive

\* accessories

\*\* under compliance of the certified ATEX conditions

\* accessories

# FPO 80

## Tank truck vane pump



### FPO... 80-700 -900

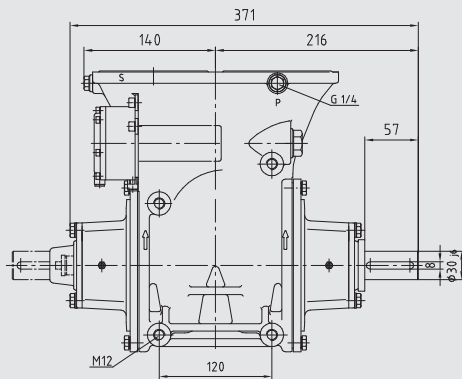

### Dimensions

#### FPO G 80-

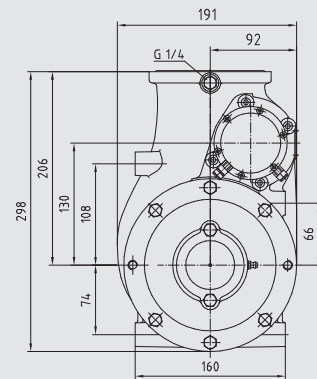

### FPO S 80-

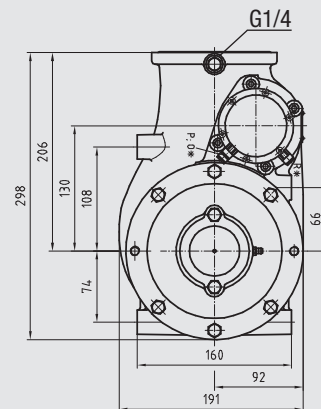
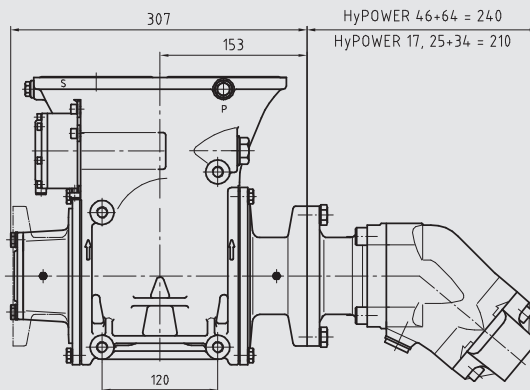

### Flow rate at $\Delta p = 10$ bar

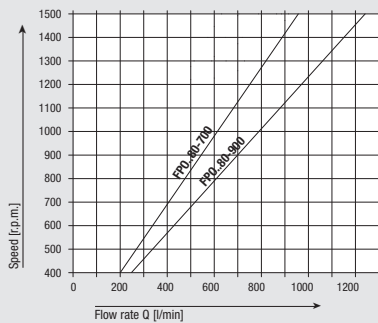

### Input power at $\Delta p = 10$ bar

The input powers of the pump are minimum values for non-viscous media with viscosities up to approx. 12 cSt as e.g. heating oil EL, diesel and motor gasoline.

